

SP

VT7D or VT7DS - B42 - 1 R 00 - A 1 M0 -

Series

VT7D series-125 A2 HW
ISO 2 bolts 3019-2 mounting flange
VT7DS series- SAE C 2 bolts
Mounting flange J744

Camring

Volumetric displacement cm³/rev (in³/rev)

B14 = 43.9 (2.68)	B31 = 99.1 (6.05)
B17 = 55.0 (3.36)	B35 = 113.4 (6.92)
B20 = 66.0 (4.03)	B38 = 120.6 (7.36)
B22 = 70.3 (4.29)	B42 = 137.5 (8.39)
B24 = 81.1 (4.95)	045 = 145.7 (8.89)
B28 = 89.9 (5.49)	050 = 157.9 (9.64)

Type of shaft VT7DS

- 1 - keyed (SAE C 32-1)
- 2 - keyed (no SAE)
- 3 - splined (SAE C 32-4)
- 4 - splined (no SAE)

Type of shaft VT7D - VT7DS

- 5 - keyed (ISO 3019-2-G32M)

Direction of rotation (view on shaft end)

- R - clockwise
- L - counter-clockwise

Modifications

Mounting w/connection variables

4 bolts SAE flange J518

P = 1-1/4" S = 2"	
UNC METRIC	
VT7D	M0
VT7DS	00 M0 Y0 ¹⁾

1) 250 bar (3630 psi) max. int.

Seal class

- 1 - S1 (for mineral oil)
- 4 - S4 (for fire resistant fluids)
- 5 - S5 (for mineral oil and fire resistant fluids)

Design letter

Porting combination

00 - standard

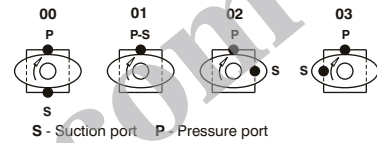

INTERNAL LEAKAGE (TYPICAL)

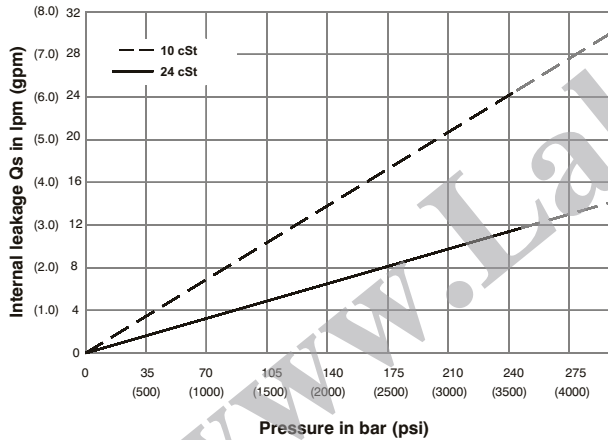

NOISE LEVEL (TYPICAL)

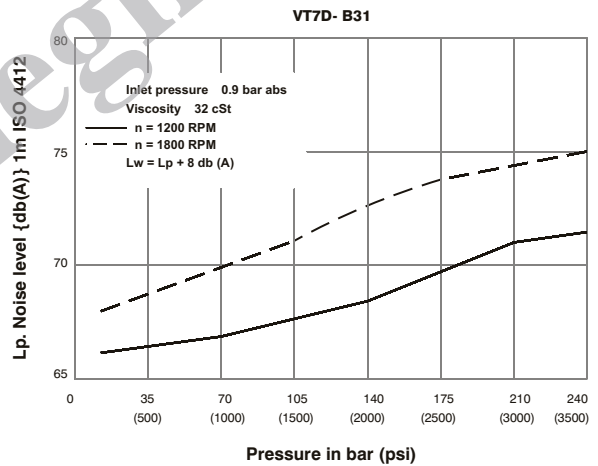

HYDROMECHANICAL POWER LOSS (TYPICAL)

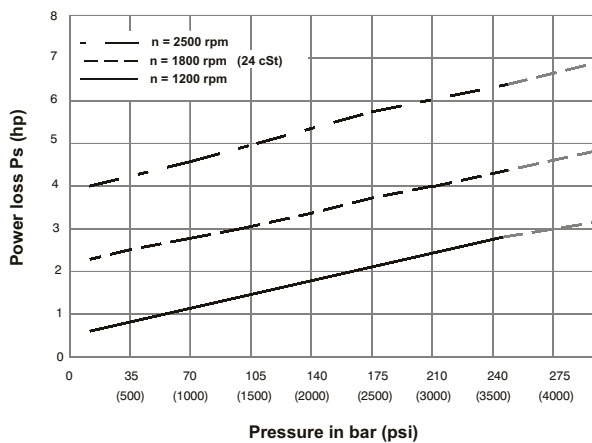

PERMISSIBLE RADIAL LOAD

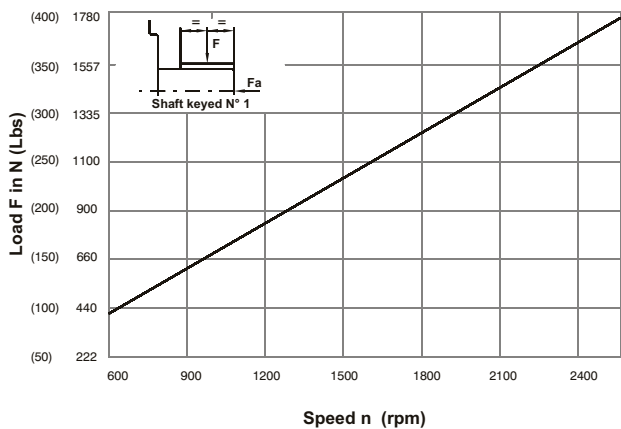

Maximum axial load permissible Fa = 1200 N (270 Lbs)

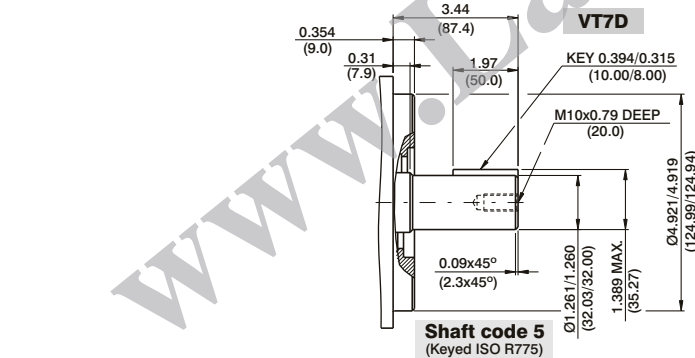
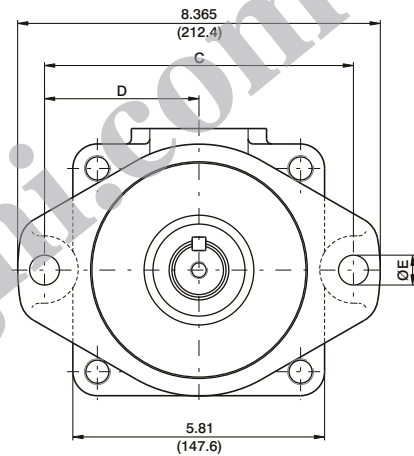
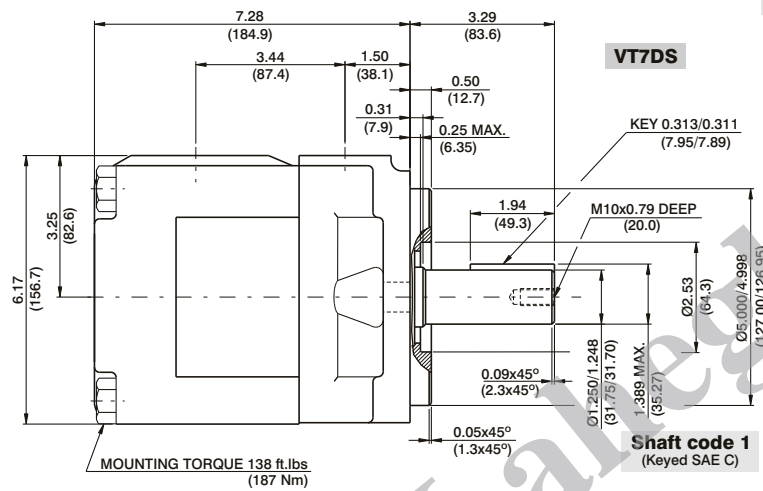
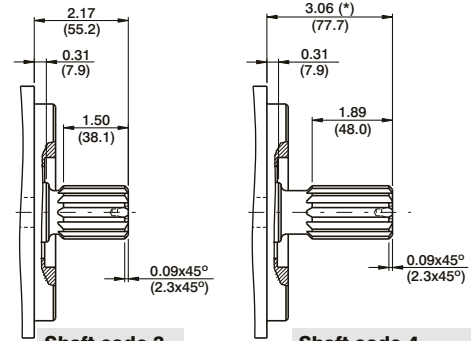
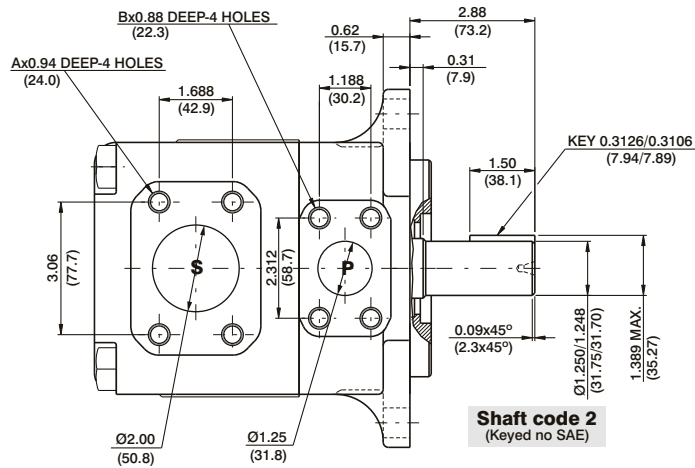

Shaft torque limits in ³ /rev x psi (ml/rev x bar)	
Shaft	Vp x p max.
1	38299 (43283)
2	30638 (34590)
3	54207 (61200)
4	54207 (61200)
5	39238 (44344)

	VT7DS		VT7D	
	00	M0	Y0 ¹⁾	M0
A	1/2-13 UNC	M12	M12	M12
B	7/16-14 UNC	M12	M10	M12
C	7.12 (181.0)		7.09 (180.0)	
D	3.56 (90.5)		3.54 (90.0)	
E	0.69 (17.5)		0.71 (18.0)	

1) 250 bar (3630 psi) max.int

OPERATING CHARACTERISTICS - TYPICAL (24 cST)

Pressure port	Series	Volumetric Displacement Vp		Flow q & n = 1800 rpm						Input power p & n = 1800 rpm							
		in ³ /rev		cm ³ /rev		p = 0 bar (0 psi)		p = 140 bar (2000 psi)		p = 300 bar (4350 psi)		p = 7 bar (100 psi)		p = 140 bar (2000 psi)		p = 300 bar (4350 psi)	
		gpm	lpm	gpm	lpm	gpm	lpm	gpm	lpm	hp	kw	hp	kw	hp	kw	hp	kw
VT7D VT7DS	B14	2.68	43.9	20.92	79.1	19.18	72.5	17.19	64.9	3.46	2.6	27.77	20.7	58.49	43.6		
	B17	3.36	55.0	26.16	98.8	24.41	92.3	22.42	84.7	3.77	2.8	33.88	25.3	71.92	53.6		
	B20	4.03	66.0	31.39	118.6	29.64	112.0	27.65	104.5	4.07	3.0	39.98	29.8	85.35	63.6		
	B22	4.29	70.3	33.43	126.4	31.69	119.8	29.70	112.3	4.19	3.1	42.37	31.6	90.60	67.6		
	B24	4.95	81.1	38.57	145.8	36.82	139.2	34.83	131.6	4.49	3.4	48.36	36.1	103.78	77.4		
	B28	5.49	89.9	42.80	161.8	41.06	155.2	39.06	147.6	4.74	3.5	53.30	39.7	114.65	85.5		
	B31	6.05	99.1	47.18	178.3	45.43	171.7	43.44	164.2	4.99	3.7	58.41	43.6	125.88	93.7		
	B35 ¹⁾	6.92	113.4	53.93	203.9	52.18	197.2	50.44	190.6	5.39	4.0	66.29	49.4	130.39	97.2		
	B38 ¹⁾	7.36	120.6	57.35	216.8	55.61	210.2	53.87	203.6	5.59	4.2	70.28	52.4	138.38	103.2		
	B42 ²⁾	8.39	137.5	65.39	247.2	63.65	240.6	62.15	234.9	6.05	4.5	79.66	59.4	149.39	111.4		
	O45 ³⁾	8.89	145.7	69.29	262.0	67.11	253.6	65.47	247.5	6.74	5.0	83.75	62.4	144.41	107.7		
	O50 ⁴⁾	9.64	157.9	75.14	284.0	72.96	275.8	71.78	271.3	7.08	5.3	90.58	67.5	134.54	100.3		

1) B35-B38 = 280 bar (4060 psi) max.int.

2) B42 = 260 bar (3770 psi) max.int.

3) O45 = 240 bar (3500 psi) max.int.

4) O50 = 210 bar (3000 psi) max.int.

* special 2"1/2 (2.5 dia) suction also available - Please contact VELJAN